

## DEVELOPMENT OF PROFESSIONAL COMPETENCE OF STUDENTS OF TECHNICAL UNIVERSITIES IN RUSSIA WHEN TRAINING IN A STUDENT DESIGN BUREAU

<sup>a</sup>VILIAM ĎURIŠ, <sup>b</sup>ANNA TIRPÁKOVÁ, <sup>c</sup>SERGEY G. CHUMAROV, <sup>d</sup>LIDIA N. VASILEVA

<sup>a</sup>*Department of Mathematics, Constantine The Philosopher University in Nitra, Tr. A. Hlinku 1, 949 74 Nitra, Slovakia*

<sup>b</sup>*Department of School Education, Tomas Bata University in Zlín, Faculty of Humanities, Štefánikova 5670, 760 01 Zlín, Czech Republic*

<sup>c</sup>*Department of Radio Engineering, Chuvash State University, 428015 Cheboksary, Russia*

<sup>d</sup>*Department of automation and management in technical systems, Chuvash State University, 428015 Cheboksary, Russia*  
email: <sup>a</sup>vduris@ukf.sk, <sup>b</sup>atirpakova@gmail.com, <sup>c</sup>chumarov@mail.ru, <sup>d</sup>oln2404@mail.ru

**Abstract:** The article substantiates the possibility of developing the professional competence of students of technical universities when studying in a student design bureau. An analysis is conducted of theoretical works and practical activities in the aspect of the problem being developed. The approaches of scientists to the definition and content of the concept of professional competence are considered. On the basis of the analysis of the professional standard 06.005 – Radio-electronics engineer, a number of professional competencies have been identified, the formation of which is carried out during training in the student design bureau. It is argued that the process of readiness for the implementation of training should include objective, motivational, informative, operational, evaluative and effective components. The results of the experiment to estimate the effectiveness of the formation of professional competence are given, indicating that training in the student design bureau contributes to the formation of students' professional competence. The generalised experience in the article aims to develop an approach to improve and further develop an effective methodology for the formation of general professional education in engineering.

**Keywords:** engineering education, vocational training, competence-based approach, student design bureau, research work, technical creativity, educational process

### 1 Introduction

Modern training of bachelors of science of technical universities, ready to carry out research, technological, organisational, managerial and design work and ensure the functioning of complex technical systems that are capable of developing fundamentally new technological approaches, is a pressing issue in education.

The concept of modernisation of Russian education for the period up to 2025 contains innovations that will affect such aspects of higher education as the formation of the personality of future graduates, taking into account personality-oriented vocational education, the motivational and needful sphere, inclinations and professional preferences, and the prospect of further growth in terms of implementing their ideas and systematically improving their qualifications [1].

One of the effective forms of training highly qualified specialists is the student design bureau (SDB), which is focused on the development of students' autonomy and responsibility for the results of their activities [2].

The purpose of the study is to substantiate the possibility of developing the professional competence of students of technical universities when studying at the SDB. The relevance of the investigation is the need to develop ways to improve the level of professional competence of students of technical universities and quality training of engineering personnel for enterprises and organisations.

Educational robotics as a factor in the development of network interaction in the system of level engineering training is considered in [2]. Based on the analysis of academic studies and practical experience, the article [3] considers the main approaches (student-centred, systemic, competence-based and integrative) of engineering education and training of engineering personnel for high-tech industries. The influence of the SDB on the quality of the educational process is reflected in the work of N.A. Logvinova, E.G. Fisochenko [4] and A.A. Samodurov [5]. The SDB as a factor in the formation of students' professional

competencies are analyzed in [6]. The development of an engineering orientation of high school students when studying in the field of radio electronics and automation was considered by the authors in [7]. A computer learning assisted tool called ISETL (Integrated System for Electronics Technology Learning) has been developed to facilitate the Electronics fundamentals understanding [8]. In [9] authors describe the research that used constructivist principles to help foster the development of assessment competence through a cycle of action/critical reflection/revised action within an assessment portfolio design. In [10] identified which competences should be developed in these engineering courses to contribute to the resolution of conflicts related to sustainability, as well as the means used by universities for their development. In [11] author presents a theoretically formulated model for development and growth of professional competence in students of technical universities.

However, to date the problem of the formation of professional competence of students of technical universities when studying in student design bureaus has not been sufficiently developed. The analysis of theoretical works and practical activities in the aspect of this problem showed that issues related to engineering education remain today an insufficiently studied area of scientific knowledge and practical activity, which made it possible to formulate a hypothesis for studying this problem: the formation of students' professional competence will be more effective if the studying process of future bachelors of science is based on the SDB.

### 2 Research methods

In the process of the research we used the following methods:

- theoretical (systematisation and generalisation, analysis of pedagogical and methodical literature, normative and program-methodical documentation, Internet resources; forecasting and design);
- diagnostic (questioning, testing);
- empirical (pedagogical observation);
- experimental (pedagogical experiment);
- methods of mathematical statistics.

The experimental basis of the study was The Federal State Educational Establishment of Higher Education "The Chuvash state university named after I. N. Ulyanov".

The study of the problem was conducted in three stages:

- in the first stage, a theoretical analysis of the existing methodological approaches in the psychological and methodological scientific literature was carried out, highlighting the problem, idea, purpose and methods of research and a plan of experimental research;
- in the second stage, an SDB-based training system was developed, and a complex of components of this system was developed and substantiated for training students of technical universities;
- in the third stage, experimental work was carried out, the conclusions analyzed, verified and refined, and the results were generalised and incorporated into the system.

### 3 Results of the research

Currently, the problem of the importance of modern engineering education is to develop ways of improving the level of professional competence. Professional competence is understood to be an integral characteristic, determining the ability of a specialist to solve professional problems and typical professional tasks arising in real situations of professional activity, using knowledge, professional and life experience and values and inclinations [12].

The following approaches of scientists to the definition and content of the concept of professional competence is shown in Table 1.

Table 1. Definition and content of the concept of professional competence

Author	Definition and content of the concept of professional competence
L.N. Zhurbenko [13]	An integrated set of fundamental and professionally significant knowledge of a specialist, ensuring its effective use in labour activity
N.I. Zaprudskiy [14]	The set of knowledge, skills and abilities, professionally significant qualities of a specialist, ensuring the ability to perform professional duties of a certain level
E.F. Zeer [15]	The combination of professional knowledge and skills, as well as ways to perform practical activities
V.M. Monahov [16]	The state allows to act independently and responsibly, to be able to perform functions related to the result of human labour
Yu.P. Povarenkov [17]	The state of adequate performance of a professional task
M.A. Choshanov [18]	The gradual updating of knowledge, the study of new information for successful use in certain situations, the ability to apply this knowledge in professional activities, the ability among the mass of decisions to choose the most optimal; reasonably reject the erroneous decision
N.P. Churlyayeva [19]	Integrated characteristic of business and personal qualities of a specialist, reflecting the level of knowledge, skills and experience necessary and sufficient to achieve the goal of work, as well as the level of functional and professional literacy
L.V. Shmelkova [20]	Integrative personality trait, expressed in the unity of theoretical, practical and motivational readiness for activity

Based on the analysis of the considered interpretations of the definition of the concept of professional competence, the following most general views of the researchers can be identified:

- professional competence is an integral characteristic of professionalism, representing both the quality of a person and the professional-personal quality based on fundamental scientific knowledge, practical skills, and skills certifying the readiness and ability of a specialist to successfully carry out professional activities;
- the level of formation of the professional competence of the individual is assessed relative to the norms and standards currently adopted in society;
- professional competence, as a rule, is expressed in the level of possession of professional knowledge and skills, in the motives, aspirations and value orientations of a specialist, and in his/her abilities to realise professional knowledge and skills in his/her work.

Consequently, the concept of professional competence is defined as the ability to solve a specific type of task, correlated with real-life production situations.

To solve the problem of the formation of the professional competence of students of technical universities at the Faculty of Radio Electronics and Automation, an SDB was created in which students are faced with the complex and at the same time interesting tasks of designing radio electronic systems and

communication systems in the direction of their professional activities.

The professional competence of students of technical areas of training is considered by this study's authors as an integrative property of the individual, based on the possession of a set of specific competencies. Analysis of the professional standard 06.005 – Radio-electronics engineer [21] allowed for identifying a number of professional competencies, the formation of which is carried out during training in the SDB:

- development and coordination of technical specifications for the design of technical conditions, programs and test methods for electronic devices and systems;
- development of structural and functional circuits of radio-electronic systems and complexes, schematic diagrams of devices using computer-aided design (CAD) tools, carrying out design calculations and a feasibility study of the decisions made;
- preparation of design and technical documentation, including manuals, test programs and specifications;
- adjustment, testing and commissioning of prototypes of electronic devices and systems.

The main goals of an SDB is: the creation of a set of conditions for the development of professional competence of undergraduate students; implementation of the system of continuous training "Electronics club" - "SDB" [22]; the transfer of basic knowledge and basic practical skills in the field of radio engineering; learning the basics of radio design; and the use of computers in the field of radio electronics and telecommunications [23]. SDB objectives include:

- improving the quality of training of future bachelors of science on the basis of the achievement by the students of the latest results of science and technology and the development of their collective creative skills;
- deepening and consolidating knowledge in the subjects of the professional cycle, instilling the skills of design and engineering activities;
- involving students in innovation activities.

For the formation of a competitive specialist, there is a need for the proper organisation of student research and training activities based on the following principles:

- interest in the study increases the opportunities for professional creativity and practical self-realisation;
- development of cognitive interest by solving engineering problems, which makes it possible to record the theoretical knowledge obtained [24];
- development of skills in working with information, along with the ability to conduct its search and processing;
- the formation of elements of research activities as a component of professional competencies.

Studying and solving problems of science and technology at the SDB level contributes to the development of professional competence. The basic training method in the SDB is based on the use of the project form of education. The final goal of this approach is to provide opportunities for students to take part in specific developments so that, by the time they graduate from the university, they have something to present to a potential employer.

The essence of the formation of professional competence of a technical university student when studying at an SDB consists in the specific direction of the formed competence in the professional activity of the future bachelor of science.

The process of readiness to implement the training includes the following components (defined by us on the basis of pedagogical observation, pedagogical experiment, own pedagogical experience):

- the objective component,

- the motivational component,
- the informative component,
- the operational component, and
- the evaluative and effective component.

The objective component is the predicted result of activity - the formation of professional competence. The motivational component is the motivation for activity, which includes an interest in a particular activity; this component can be internal, generated by the activity itself, and external, arising during the exchange of activities. The informative component is the unity of all the constituent elements of an object, its properties, internal processes and connections. This component is reflected in the work program in the SDB mode; in the degree of creative orientation of educational activities; in the formation of motivational attitudes and personality orientation; and in educating students. The operational component is that the student has theoretical and practical knowledge of the fundamentals of basic and applied sciences, ensuring the possibility of achieving results in professional activities as well as the possession of forms, methods and means of achieving results. The evaluative and effective component includes diagnostics of the level of formation of students' professional competence when training in the SDB, combines the assessment of the tutor and the student's self-assessment of the studying outcomes, establishes their compliance with the goals, identifies the core directions of improving the learning process, and sets tasks for further activities.

Let us give an example of a project being solved by students in the area of preparation of 11.03.01 "Radio Engineering" at an SDB. This task is carried out on the basis of studying the features of work and characteristics of specific elements and engineering devices on real-life models – e.g. an audio amplifier, direct-conversion receiver (DCR) or power source. Speaking, for example, about the DCR, the trainer recalls information about self-induction and capacity already acquired from the physics course.

For training purposes, considerable importance is attached to computer modelling and design and the use of application software packages e.g. Altium Designer [25] for modelling electronic circuits and designing printed circuit boards, with the subsequent formation of a conductive pattern for the manufacture of prototypes of devices using printed-circuit technique with laser printer and iron. For example, the first practical lesson is the manufacture of a prototype of a symmetric multivibrator with subsequent experimental study of its characteristics. Figure 1 shows a circuit of a multivibrator drawn in the schematic editor Altium Designer.

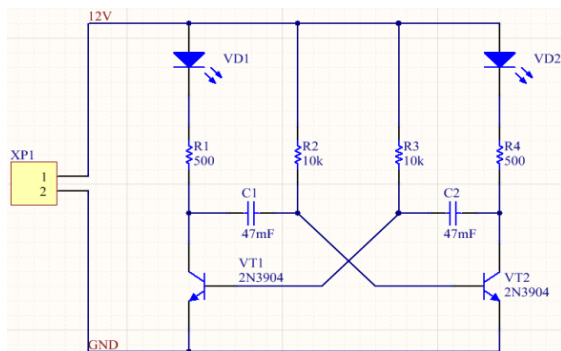
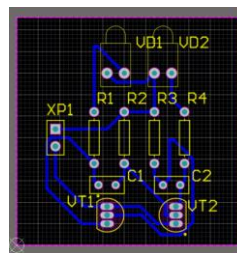

Figure 1. The circuit of a multivibrator

A symmetric multivibrator is a device with the pairwise equality of the resistances of the resistors R1 and R4, R2 and R3, the capacitances of the capacitors C1 and C2, as well as the parameters of the transistors VT1 and VT2. A symmetric multivibrator generates rectangular oscillations ("meander") with a duty cycle of 2 i.e. a rectangular signal in which the pulse duration and pause duration are the same. The pulse duration is  $\tau_1 = R2C1$  and  $\tau_2 = R3C2$ .

Next, a single-layer printed circuit board is routed in PCB editor (Figure 2a). Single-layer routing of the PCB greatly simplifies the process of its self-production by chemical method without metallisation of through holes. The components of the multivibrator correspond to the through-hole technology; this technology makes it easy to install components on the board and have access to the circuits of the multivibrator under study during the experiment. Surface mounting technology - due to its small size - as an initial experience has limited application. However, in subsequent classes the use of such technology is assumed, both in simple form and in conjunction with the through-hole technology. To build a PCB, it is necessary to prepare a file (Figure 2b).



(a)

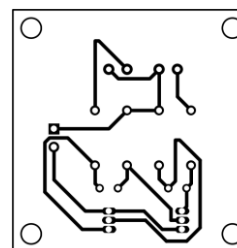

(b)

Figure 2. Printed circuit board

The experimental work to assess the effectiveness of the formation of professional competence was carried out in Chuvash State University, while the experiment was conducted under normal conditions of training with respect to the homogeneity of the respondents. 43 students of the Faculty of Radio Electronics and Automation were respondents in the experiment. The students were randomized into two groups: Experimental group (22 students) and control group (21 students). While the control group students were taught in the classical way according to the curriculum of the Faculty of Radio Electronics and Automation, which is oriented to professional standard 06.005 – Radio-electronics engineer, the experimental group students took the curriculum using SDB. Classes in the SDB were held in the third year of undergraduate studies for one hour a week.

The tool for diagnosing professional competence in the study are the results of an oral survey, questionnaires and the performance of a design project.

To assess the effectiveness of the formation of professional competence, the following levels were identified: high, advanced, basic.

Indicators of the high level of development of the respondents' competence include: possession of the basic laws of natural science subjects and the method of theoretical and experimental research, allowing to logically defend the product of research; knowledge of information and communication technology tools and the ability to apply them in a work situation; and the knowledge of modern software packages and the ability to create software products for solving professional problems.

Indicators of the advanced level of development include: the ability to analyze the software of the field of study and the possession of theoretical and experimental research methods; knowledge of various ways of collecting, processing and presenting information, as well as the ability to bring

information into a convenient form for perception; and the ability to work with various software products, using them in solving educational and production problems.

Indicators of the basic level of development include: the ability to independently solve various problems of natural science subjects using methods of mathematical modelling; knowledge of software tools for automated receiving and processing of collected information; the ability to work with a personal computer, competently using specific software products in computer modelling.

Levels of formation of professional competence of students of the experimental and control groups are listed in Table 2.

Table 2. Levels of formation of professional competence of students of the experimental and control groups

Subgroups	Levels		
	basic	advanced	high
experimental	3	10	9
control	10	8	3

We also verified the effectiveness of this method of study using statistical methods. To verify the dependence of the two quality variables  $A$ ,  $B$ , where  $A$  are groups of students and  $B$  are Levels of formation of professional competence of students, we used the statistical method of  $\chi^2$ -test of independence for the contingency table type of  $k \times m$ . It is assumed that variable  $A$  takes on  $k = 2$  levels: experimental and control group, and character  $B$  takes on  $m = 3$  levels: basic, advanced and high, while  $k > 2$  and  $m > 2$ .

The obtained data are arranged in a contingency table of  $k \times m$  type. The following null hypothesis  $H_0$  is tested: the variables  $A$ ,  $B$  are independent; against the alternative hypothesis  $H_1$ : the variables  $A$ ,  $B$  are dependent. The test criterion is a statistics  $\chi^2$  defined as follows:

$$\chi^2 = \sum_{i=1}^k \sum_{j=1}^m \frac{(f_{ij} - o_{ij})^2}{o_{ij}},$$

where  $f_{ij}$  are empirical frequencies and  $o_{ij}$  are expected frequencies. In the case that the tested hypothesis  $H_0$  is true, the test statistics  $\chi^2$  has  $\chi^2$ -distribution with  $r = (k - 1)(m - 1)$  degrees of freedom. The hypothesis  $H_0$  is rejected for a significance level  $\alpha$  if the value of test statistics  $\chi^2$  exceeds the critical value  $\chi^2_{\alpha}(r)$ .

By  $\chi^2$ -test of independence for contingency table  $k \times m$  we verified whether the value of the level of formation of professional competence of students depends on whether the student belongs to the experimental or control group. In our case, we calculated the value of the test criterion of  $\chi^2$ -test ( $\chi^2_{0.05}(2) = 6.972$ ). Since the calculated test criterion value exceeds the critical table value ( $\chi^2_{\alpha}(r) = 5.991$ ), we reject the hypothesis  $H_0$  at the significance level  $\alpha = 0.05$  and accept the alternative hypothesis  $H_1$ . This means that the level of formation of professional competence of students is statistically significant depending on which group the student belongs to. The test thus confirmed that the students of the experimental group achieved statistically significantly different (better) results in the levels of Formation of Professional Competence of students than the students of the control group. We have also illustrated the situation in the following figure (Figure 3).

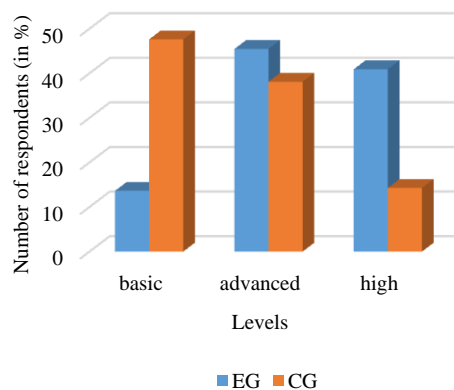

Figure 3. Results of experiment

The statistical results has confirmed that our method is effective and based on our results we can say that students' ability to solve tasks has really increased. These results really showed that it is possible to improve the students' abilities by our method.

#### 4 Conclusion

Research work in an SDB contributes to students' acquisition of the skill of working with scientific literature, experience in setting tasks, as well as the planning of an experiment and its implementation.

As such, a SDB plays an important role in the development of students' creative abilities, but also requires constant attention from the faculty to find new forms of its organisation. The trainer needs to competently organise the research work and use the appropriate educational environment for correctly directing the student to acquire knowledge.

A further perspective of the research problem will focus on solving issues related to the intensification of existing methods and technologies relevant to the development of students' professional competence in engineering education.

#### Literature:

1. Ministry of Education of the Russian Federation: *Kontseptsiya profilnogo obucheniya na starshey stupeni obschego obrazovaniya / Modernizatsiya. Shag v budushee / Uchitel'skaya gazeta*. 2011, Vol. 4. p. 13-16.
2. Cheremuhin P. S., Shumeyko A. A.: *Obrazovatel'naya robototekhnika kak faktor razvitiya setevogo vzaimodeystviya v sisteme urovnevnoy inzhenernoy podgotovki*. In: *Integratsiya obrazovaniya*, Vol. 22, No. 3., 2018, p. 535-550. DOI: 10.15507/1991-9468.092.022.201803.
3. Plutenko, A. D., Leyfa, A. V., Kozyr, A. V., Halet'skaya, T. V.: *Specific Features of Vocational Education and Training of Engineering Personnel for High-Tech Businesses*. In: *European Journal of Contemporary Education*, Vol. 7, No. 2, 2018, p. 360-371.
4. Logvinova N. A., Fisochenko E. G.: *Vliyanie studencheskogo konstruktorskogo byuro na kachestvo uchebnogo protsesssa*. In: *Urovnevaya podgotovka spetsialistov: gosudarstvennyye i mezhdunarodnyye standarty inzhenernogo obrazovaniya sbornik trudov Nauchno-metodicheskoy konferentsii, Natsionalniy issledovatel'skiy Tomskiy politehnicheskii universitet*. 2013, p. 348-349.
5. Samodurov A. A.: *Studencheskoe konstruktorskoe byuro*. In: *Molodezh i sotsium, Tambovskiy gosudarstvenniy universitet imeni G.R. Derzhavina*, Vol. 14, 2013, p. 69-74.
6. Fot Z. A., Kosova E. V.: *Studencheskie konstruktorskie byuro kak faktor formirovaniya professionalnykh kompetentsiy obuchayuschihsiya*. In: *Ekonomika sferyi servisa: problemyi i perspektivy. Materialy III Mezhvuzovskoy nauchno-prakticheskoy konferentsii, Omsk, Omskiy gosudarstvenniy tehnikeskii universitet*, 2017, p. 100-102.

7. Vasileva L. N., Chumarov S. G.: *Razvitie professionalno-tehnicheskoy orientatsii uchaschihsya starshih klassov pri obuchenii v radiokruzhke*. In: Vektor nauki Tolyattinskogo gosudarstvennogo universiteta, Seriya: Pedagogika, psihologiya. Vol. 1, No. 28, 2017, p. 9-14.
8. Santos, G., Mandado, E., Silva, R., Doiro, M.: *Engineering learning objectives and computer assisted tools*. In: European Journal of Engineering Education, Vol. 44, No. 4, 2019, p. 616-628. DOI: 10.1080/03043797.2018.1563585.
9. Lalor, J. Lorenzi, F., Rami, J.: *Developing professional competence through assessment: constructivist and reflective practice in teacher-training*. In: Eurasian Journal of Educational Research, Vol. 58, 2014, p. 45-66, DOI: 10.14689/ejer.2015.58.6.
10. Quelhas, O. L. G., Lima, G. B. A., Ludolf, N. V. E., Meiriño, M. J., Abreu, C., Anholon, R., Vieira N. J., Rodrigues, L. S. G.: *Engineering education and the development of competencies for sustainability*. In: International Journal of Sustainability in Higher Education, Vol. 20, No. 4, 2019, p. 614-629. DOI: 10.1108/IJSHE-07-2018-0125.
11. Izvorska, D.: *A model for development of professional competence in students of technical institutes of higher learning*. In: 16th Conference on Electrical Machines, Drives and Power Systems (ELMA), 2019, DOI: 10.1109/ELMA.2019.8771682.
12. Kozyreva, V. A., Radionovoy, N. F.: *Kompetentnostnyy podhod v pedagogicheskom obrazovanii: kollektivnaya monografiya*. SPb: Izdatelstvo RGPU im. A.I. Gertsena, 2004, 392 p.
13. Zhurbenko, L. N.: *Didakticheskaya sistema gibkoy mnogoprofilnoy matematicheskoy podgotovki v tehnologicheskoy universitete: dis. d-ra ped. nauk*. Kazan, 2000, 451 p.
14. Zaprudskiy, N. I.: *Nauchno-pedagogicheskoe obespechenie povysheniya kvalifikatsii uchiteley estestvenno-matematicheskikh predmetov: dis. d-ra ped. nauk*. Minsk, 1993, 36 p.
15. Zeer, E. F.: *Psihologiya professiy: uchebnoe posobie dlya studentov vuzov*. Akademicheskij Proekt, Ekaterinburg: Delovaya kniga, 2003, 336 p.
16. Monahov, V. M., Nizhnikov, A. I.: *Proektirovanie traektoriy stanovleniya buduschego uchitelya*. In: Shkolnyie tehnologii. Vol. 6., 2000, p. 36-45.
17. Povarenkov, Y. P.: *Psihologicheskoe sodержanie professionalnogo stanovleniya cheloveka*. Moskva: URAO, 2002, 160 p.
18. Choshanov, M. A.: *Gibkaya tehnologiya problemno-modulnogo obucheniya*. Moskva: Narodnoe obrazovanie, 1996, 157 p.
19. Churlyayeva, N. P.: *Obespechenie kachestva podgotovki inzhenerov v ryinochnyih usloviyah na osnove kompetentnostnogo podhoda: spetsialnost 13.00.01, 13.00.08 «Obschaya pedagogika, istoriya pedagogiki i obrazovaniya», «Teoriya i metodika professionalnogo obrazovaniya»*. avtoref. dis., Krasnoyarsk, 2008, 44 p.
20. Shmelkova, L. V.: *Tsel proektirovaniya – tehnologicheskaya kompetentnost pedagoga*. In: Shkolnyie tehnologii, Vol. 4, 2002, p. 36-49.
21. Prikaz Ministerstva truda i sotsialnoy zaschity RF ot 19 maya 2014 g. N 315n "Ob utverzhdenii professionalnogo standarta "Inzhener-radioelektronshik". Portal Federalnyih gosudarstvennyih obrazovatelnyih standartov vysshego obrazovaniya, URL: <http://fgosvo.ru/uploadfiles/profstandart/06.005.pdf> (date: 01.02.2019).
22. Vasileva L. N., Chumarov S. G.: *Razvitie professionalno-tehnicheskoy orientatsii uchaschihsya starshih klassov*. In: Pedagogika, Vol. 4, No. 1, 2017 p. 122-125.
23. Vasileva L. N.: *Aspektyi ispolzovaniya professionalno orientirovannyih zadach v matematicheskoy podgotovke bakalavrov tehnicheskikh fakul'tetov po napravleniyu 210300-radiotekhnika*. In: Matematika. Obrazovanie Materialy VII Mezhdunarodnoy konferentsii "Matematika. Obrazovanie" i Mezhdunarodnogo simpoziuma "Dvuyazychnoe (bilingvalnoe) obuchenie v sisteme obshego i vysshego professionalnogo obrazovaniya, 2009, 169 p.
24. Vasileva L. N., Kartuzova T. V., Merlin A. V., Merlina N. I., Svetlova N. I.: *Formation of professional-mathematical*

*competence of students in the field of technical training based on interdisciplinary integration of mathematics and computer science*. In: Mediterranean Journal of Social Sciences, Vol. 2, No. 6, 2015, p. 90-97., DOI: 10.5901/mjss.2015.v6n2s3p90. 25. PCB Design Software & Tools for Building Next-Generation Electronics URL: [www.altium.com](http://www.altium.com) (date: 02.02.2019)

**Primary Paper Section: B**

**Secondary Paper Section: BB, JD**